

Marine Fuel Filtration

Marine Turbine Series

Marine Turbine Series filter assemblies are designed to be installed on the vacuum side of the fuel transfer pump for best efficiency and protect precision engine components from dirt, rust, algae, asphaltines, varnishes, and especially water, which is prevalent in engine fuels. They remove contaminants from fuel using the following legendary three stage process:

Stage One: Separation

As fuel enters the filter assembly, it moves through the centrifuge and spins off large solids and water droplets which fall to the bottom of the collection bowl.

Stage Two: Coalescing

Small water droplets bead-up on the surface of the conical baffle and cartridge element. When heavy enough, they too fall to the bottom of the bowl.

Stage Three: Filtration

Proprietary Aquabloc®II cartridge elements repel water and remove contaminants from fuel down to 2 micron (nominal). They are waterproof and effective longer than water absorbing elements.



500MA

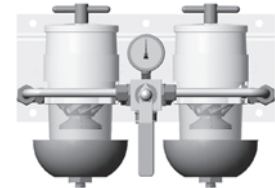

75500MAX



900MA



75900MAX



1000MA



791000MAV

And more...



Parker Hannifin Corporation
Racor Division, PO Box 3208
Modesto, CA 95354 USA
Phone: 800.344.3286
Fax: 209.529.3278
E-mail: racor@parker.com
www.parker.com/racor



Marine Fuel Filtration

Marine Turbine Series

Applies to
all models.

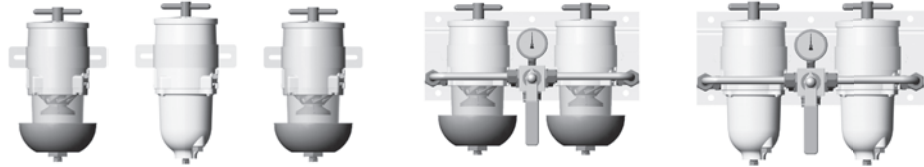

500 Series

Specifications	500MA ¹	500MAM	503MA	75500MAX	75500MAXM
Maximum Flow Rate <i>One Filter On-line</i> <i>Two Filters On-line</i>	60 GPH (227 LPH) N/A	60 GPH (227 LPH) N/A	60 GPH (227 LPH) N/A	60 GPH (227 LPH) 120 GPH (454 LPH)	60 GPH (227 LPH) 120 GPH (454 LPH)
Application	Diesel	Gasoline or Diesel	Diesel	Diesel	Gasoline or Diesel
Port Size NPTF Port Size (SAE J1926)	no 3/4"-16	no 3/4"-16	3/8" no	no 3/4"-16	no 3/4"-16
Height	11.5 in. (29.2 cm)	11.0 in. (27.9 cm)	11.5 in. (29.2 cm)	11.5 in. (29.2 cm)	11.0 in. (27.9 cm)
Width	5.8 in. (14.7 cm)	5.8 in. (14.7 cm)	5.8 in. (14.7 cm)	14.5 in. (36.8 cm)	14.5 in. (36.8 cm)
Depth	4.8 in. (12.2 cm)	4.8 in. (12.2 cm)	4.8 in. (12.2 cm)	9.5 in. (24.1 cm)	9.5 in. (24.1 cm)
Weight	4.0 lb (1.7 kg)	5.0 lb (2.2 kg)	4.0 lb (1.7 kg)	17 lb (7.7 kg)	18 lb (8.2 kg)
Clean Pressure Drop	0.3 PSI (1.7 kPa)	0.3 PSI (1.7 kPa)	0.3 PSI (1.7 kPa)	0.7 PSI (4.8 kPa)	0.7 PSI (4.8 kPa)
Maximum Pressure	15 PSI (1.0 bar)	15 PSI (1.0 bar)	15 PSI (1.0 bar)	15 PSI (1.0 bar)	15 PSI (1.0 bar)
Water Capacity	3.7 oz (110 ml)	3.7 oz (110 ml)	3.7 oz (110 ml)	7.4 oz (220 ml)	7.4 oz (220 ml)
Overhead Clearance	4.0 in. (10.2 cm)	4.0 in. (10.2 cm)	4.0 in. (10.2 cm)	4.0 in. (10.2 cm)	4.0 in. (10.2 cm)
Water Removal Efficiency	99%	99%	99%	99%	99%
Operating Temperature	-40° to +255°F (-40° to +121°C)				

¹ Optional 16MM ports.

RACOR

Technical Support:
800.344.3286 ext. 7555
racortech@parker.com

328



Marine Fuel Filtration

Marine Turbine Series



900 Series

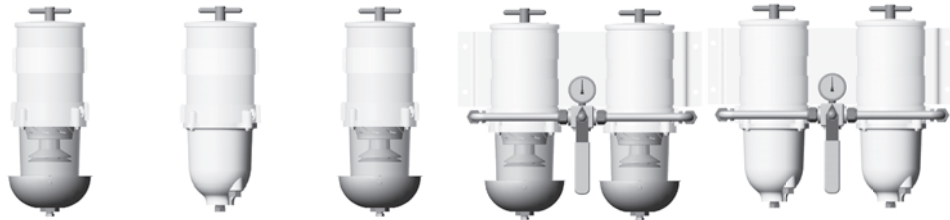

Specifications	900MA	900MAM	903MA	75900MAX	75900MAXM
Maximum Flow Rate: <i>One Filter On-line</i>	90 GPH (341 LPH)	90 GPH (341 LPH)	90 GPH (341 LPH)	90 GPH (341 LPH)	90 GPH (341 LPH)
<i>Two Filter On-line</i>	N/A	N/A	N/A	180 GPH (681 LPH)	180 GPH (681 LPH)
Application	Diesel	Gasoline or Diesel	Diesel	Diesel	Gasoline or Diesel
Port Size	3/8"-14 (SAE J1926)	3/8"-14 (SAE J1926)	BSPT 1/2"-14	3/8"-14 (SAE J514)	3/8"-14 (SAE J514)
Height	17.0 in. (43.2 cm)	16.5 in. (41.9 cm)	17.0 in. (43.2 cm)	17.0 in. (43.2 cm)	16.5 in. (41.9 cm)
Width	6.0 in. (15.2 cm)	6.0 in. (15.2 cm)	6.0 in. (15.2 cm)	18.8 in. (47.6 cm)	18.8 in. (47.6 cm)
Depth	7.0 in. (17.8 cm)	7.0 in. (17.8 cm)	7.0 in. (17.8 cm)	11.0 in. (27.9 cm)	11.0 in. (27.9 cm)
Weight	6.0 lb (2.7 kg)	7.0 lb (3.2 kg)	6.0 lb (2.7 kg)	23 lb (10.4 kg)	24 lb (10.9 kg)
Clean Pressure Drop	0.34 PSI (2.4 kPa)	0.34 PSI (2.4 kPa)	0.34 PSI (2.4 kPa)	1.7 PSI (11.7 kPa)	1.7 PSI (11.7 kPa)
Maximum Pressure	15 PSI (1.0 bar)	15 PSI (1.0 bar)	15 PSI (1.0 bar)	15 PSI (1.0 bar)	15 PSI (1.0 bar)
Water Capacity	10.3 oz (305 ml)	10.3 oz (305 ml)	10.3 oz (305 ml)	20.6 oz (610 ml)	20.6 oz (610 ml)
Overhead Clearance	5.0 in. (12.7 cm)	5.0 in. (12.7 cm)	5.0 in. (12.7 cm)	5.0 in. (12.7 cm)	5.0 in. (12.7 cm)
Water Removal Efficiency	99%	99%	99%	99%	99%
Operating Temperature	-40° to +255°F (-40° to +121°C)				



Marine Fuel Filtration

Marine Turbine Series

Applies to
all models.



1000 Series



Specifications	1000MA	1000MAM	1003MA	731000MA	731000MAM
Maximum Flow Rate: <i>One Filter On-line</i>	180 GPH (681 LPH)	180 GPH (681 LPH)	180 GPH (681 LPH)	N/A	N/A
<i>Two Filters On-line</i>	N/A	N/A	N/A	360 GPH (1363 LPH)	360 GPH (1363 LPH)
Application	Diesel	Gasoline or Diesel	Diesel	Diesel	Gasoline or Diesel
Port Size	3/8"-14 (SAE J1926)	3/8"-14 (SAE J1926)	BSPT 1/2"-14	3/4"-14 (SAE J476)	3/4"-14 (SAE J476)
Height	22.0 in. (55.9 cm)	21.5 in. (54.5 cm)	22.0 in. (55.9 cm)	22.0 in. (55.9 cm)	21.5 in. (54.5 cm)
Width	6.0 in. (15.2 cm)	6.0 in. (15.2 cm)	6.0 in. (15.2 cm)	16.5 in. (41.9 cm)	16.5 in. (41.9 cm)
Depth	7.0 in. (17.8 cm)	7.0 in. (17.8 cm)	7.0 in. (17.8 cm)	12.0 in. (30.5 cm)	12.0 in. (30.5 cm)
Weight	10 lb (4.5 kg)	11 lb (5.0 kg)	10 lb (4.5 kg)	26 lb (11.8 kg)	27 lb (12.2 kg)
Clean Pressure Drop	0.5 PSI (3.4 kPa)	0.5 PSI (3.4 kPa)	0.5 PSI (3.4 kPa)	1.7 PSI (11.7kPa)	1.7 PSI (11.7 kPa)
Maximum Pressure	15 PSI (1.0 bar)	15 PSI (1.0 bar)	15 PSI (1.0 bar)	15 PSI (1.0 bar)	15 PSI (1.0 bar)
Water Capacity	10.3 oz (305 ml)	10.3 oz (305 ml)	10.3 oz (305 ml)	20.6 oz (610 ml)	20.6 oz (610 ml)
Overhead Clearance	10.0 in. (25.4 cm)	10.0 in. (25.4 cm)	10.0 in. (25.4 cm)	10.0 in. (25.4 cm)	10.0 in. (25.4 cm)
Water Removal Efficiency	99%	99%	99%	99%	99%
Operating Temperature	-40° to +255°F (-40° to +121°C)				

RACOR

Technical Support:
800.344.3286 ext. 7555
racortech@parker.com

330



Marine Fuel Filtration

Marine Turbine Series

2

Applies to
all models.

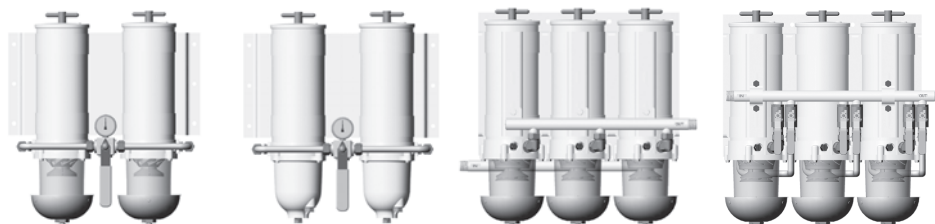

1000 Series

Specifications	751000MAX	751000MAXM	771000MA	791000MAV
Maximum Flow Rate: <i>One Filter On-line</i> <i>Two Filters On-line</i> <i>Three Filters On-line</i>	180 GPH (681 LPH) 360 GPH (1363 LPH) N/A	180 GPH (681 LPH) 360 GPH (1363 LPH) N/A	N/A N/A 540 GPH (2044 LPH)	180 GPH (681 LPH) 360 GPH (1363 LPH) 540 GPH (2044 LPH)
Application	Diesel	Gasoline or Diesel	Diesel	Diesel
Port Size	3/8"-14 (SAE J514)	3/8"-14 (SAE J514)	1"-11.5 (SAE J476)	3/4"-14 (SAE J476)
Height	22.0 in. (55.9 cm)	21.5 in. (54.6 cm)	22.0 in. (55.9 cm)	22.0 in. (55.9 cm)
Width	18.8 in. (47.6 cm)	18.8 in. (47.6 cm)	21.5 in. (54.6 cm)	21.5 in. (54.6 cm)
Depth	11.0 in. (27.9 cm)	11.0 in. (27.9 cm)	12.0 in. (30.5 cm)	11.8 in. (30.0 cm)
Weight	30 lb (13.6 kg)	31 lb (14.1 kg)	39 lb (17.7 kg)	52 lb (23.6 kg)
Clean Pressure Drop	3.7 PSI (25.5 kPa)	3.7 PSI (25.5 kPa)	1.7 PSI (11.7 kPa)	2.5 PSI (17.2 kPa)
Maximum Pressure	15 PSI (1.0 bar)	15 PSI (1.0 bar)	15 PSI (1.0 bar)	15 PSI (1.0 bar)
Bowl Capacity	20.6 oz (610 ml)	20.6 oz (610 ml)	30.9 oz (915 ml)	30.9 oz (915 ml)
Overhead Clearance	10.0 in. (25.4 cm)	10.0 in. (25.4 cm)	10.0 in. (25.4 cm)	10.0 in. (25.4 cm)
Water Removal Efficiency	99%	99%	99%	99%
Operating Temperature	-40° to +255°F (-40° to +121°C)			



Marine Fuel Filtration

Marine Turbine Series

How to Order

(The example below illustrates how the part numbers are constructed).

500MA	M	10
Basic Model Optional 16MM ports Use model 503MA for 3/8" NPTF Pipe Thread	Add M for metal bowl.	Specify: 2 (for 2 micron) 10 (for 10 micron) 30 (for 30 micron)

Replacement Element (seals included)		
2010SM-OR	2 micron	Final
2010TM-OR	10 micron	Secondary
2010PM-OR	30 micron	Primary ¹

¹ A secondary or final filter is required downstream.

Mounting Information

500MA
Certifications



USCG

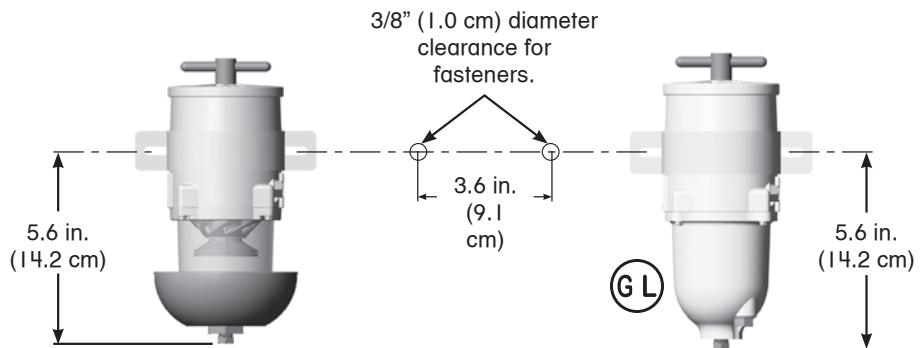

RACOR

Technical Support:
800.344.3286 ext. 7555
racortech@parker.com

332



Marine Fuel Filtration

2

Marine Turbine Series Replacement Parts

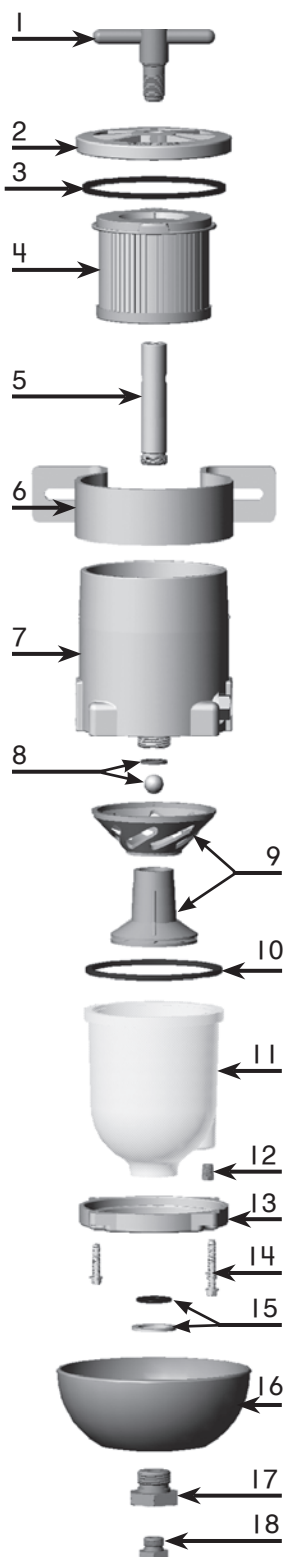

500MA and 503MA

Part Number	Description
1. RK11888	T-handle Kit (includes o-ring)
11350	T-handle O-ring
2. RK15078-02	MA Lid Kit (white) (includes #3)
3. 15005	Lid Gasket
4. Replacement Elements (includes #3)	
2010SM-OR	2 Micron
2010TM-OR	10 Micron
2010PM-OR	30 Micron
5. RK15079	Return Tube Kit
6. RK15090	Mounting Bracket Kit
7. RK15377-01	Body Kit (3/4"-16 UNF Ports)
15418-09	500MA Body (16MM ports)
15418-10	503MA Body (3/8" NPTF Ports)
8. RK15010B	Checkball Kit (includes seal)
9. RK15013D	Turbine/Centrifuge Kit
10. 15374	Bowl Gasket
11. RK15279-01	Clear Bowl Kit (includes #9)
RK15301-01	Metal Bowl Kit (includes #9)
12. RK20022	Port Plug Kit
13. 15035-02	Bowl Ring (includes #16)
14. RK15081	Capscrew Kit (10-24 x 7/8") (includes 4 capscrews)
15. RK11340	Drain Fitting O-ring Kit
16. RK15104¹	Heat Deflector Shield Kit (includes #'s 12, 14 & 15)
17. 918-N4	Drain plug (1/4" NPT)
18. RK11-1910	Drain Fitting Kit (includes #'s 12 & 15)

Additional Parts (not shown)

RK11341	Drain Washer
RK19492	Marine Shut-off Valve Kit
RK21069²	Water Probe Kit
RK15211	Complete Seal Service Kit
15335	Installation Instructions

¹For replacement only. The Coast Guard does not accept 'FH' units converted to 'MA' configurations.

²For diesel service only. Must be used with a water Detection Kit.

Marine Fuel Filtration

Marine Turbine Series

How to Order

(The example below illustrates how the part numbers are constructed).

900MA	M	10
<p>Basic Model Number</p> <p>Use model 903MA for 1/2"-14 BSPT pipe thread</p>	<p>Add M for metal bowl.</p>	<p>Specify:</p> <p>2 (for 2 micron)</p> <p>10 (for 10 micron)</p> <p>30 (for 30 micron)</p>

Replacement Element (seals included)		
2040SM-OR	2 micron	Final
2040TM-OR	10 micron	Secondary
2040PM-OR	30 micron	Primary ¹

¹ A secondary or final filter is required downstream.

Mounting Information

900MA
Certifications



USCG

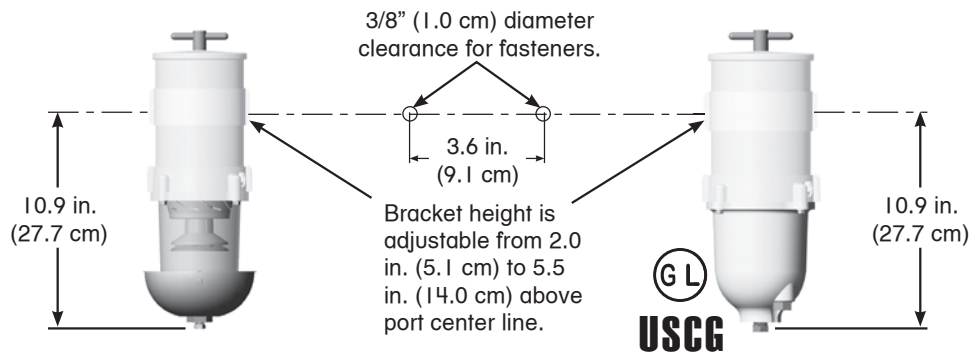

RACOR

Technical Support:
800.344.3286 ext. 7555
racortech@parker.com

334



Marine Fuel Filtration

2

Marine Turbine Series

Replacement Parts

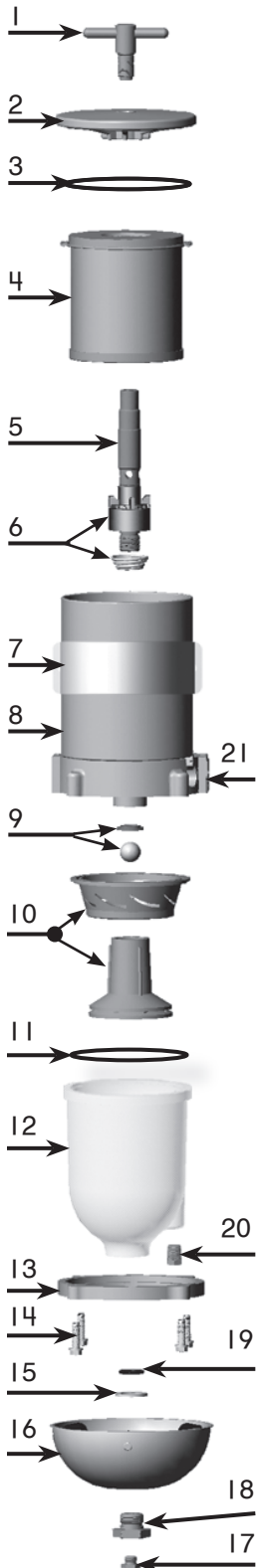

900MA and 903MA

Part Number	Description
1. RK11888	T-handle Kit (includes o-ring)
11350	T-handle O-ring
2. RK11-1933-04	Lid Kit (includes #3)
3. 11007	Lid O-ring
4. Replacement Element (includes #3)	
2040SMOR	2 Micron Element
2040TMOR	10 Micron Element
2040PMOR	30 Micron Element
5. RK11-1931	Return Tube Kit
6. RK11-1953	Valve, Spring & O-ring Kit
7. RK11815-101	Body Clamp Bracket Kit
8. RK19002	Outer Cylinder Kit (includes #'s 8 and 9)
9. RK11028B	Checkball and Seal Kit
10. RK11026D	Turbine/Centrifuge Kit
11. 11007	Bowl O-ring
12. RK11-1606-1	Clear Bowl Kit (includes #10)
RK11734	Metal Bowl Kit
RK11734-01	Metal Bowl Kit (1/4" NPT)
13. RK11037A	Bowl Ring Kit
14. RK11542	Capscrew Kit (1/4"-20 x 1") (includes 4 capscrews)
15. RK11341	Bowl Drain Gasket Kit
11041	Bowl Drain Washer
16. RK11868 ¹	Heat Deflector Shield (includes #'s 13-16)
17. 918-N4	Bowl Plug (1/4" NPT)
18. RK11-1910	Drain Fitting Kit
19. RK11340	Drain O-ring Kit
20. RK20022	Port Plug Kit
21. 11-1853-16	Base with 1/2"-14 BSPT ports

Additional Parts (not shown)

RK19492	Marine Shut-off Valve Kit
RK21069	Water Probe Kit
RK11-1679	Plastic Body Plug Kit
RK11-1404	Complete Seal Service Kit
19526	Installation Instructions

¹For replacement only. The Coast Guard does not accept 'FH' units converted to 'MA' configurations.

Marine Fuel Filtration

Marine Turbine Series

How to Order

(The example below illustrates how the part numbers are constructed).

1000MA	M	10
Basic Model Use model 1003MA for 1/2"-14 BSPT pipe thread	Add M for metal bowl.	Add: 2 (for 2 micron) 10 (for 10 micron) 30 (for 30 micron)

Replacement Element (seals included)		
2020SM-OR	2 micron	Final
2020TM-OR	10 micron	Secondary
2020PM-OR	30 micron	Primary ¹

¹ A secondary or final filter is required downstream.

Mounting Information

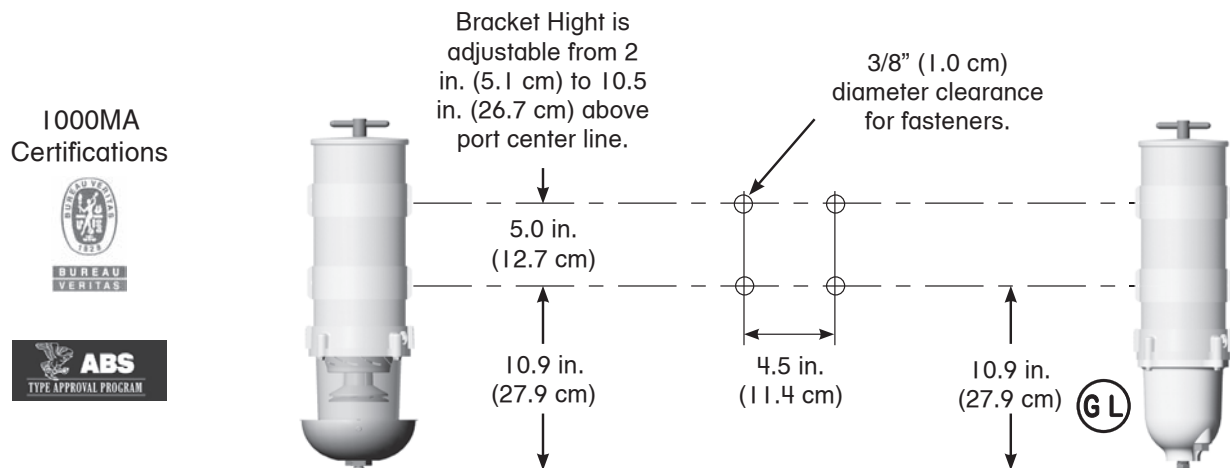

RACOR

Technical Support:
800.344.3286 ext. 7555
racortech@parker.com

336

Parker

Marine Fuel Filtration

Marine Turbine Series

Replacement Parts

2

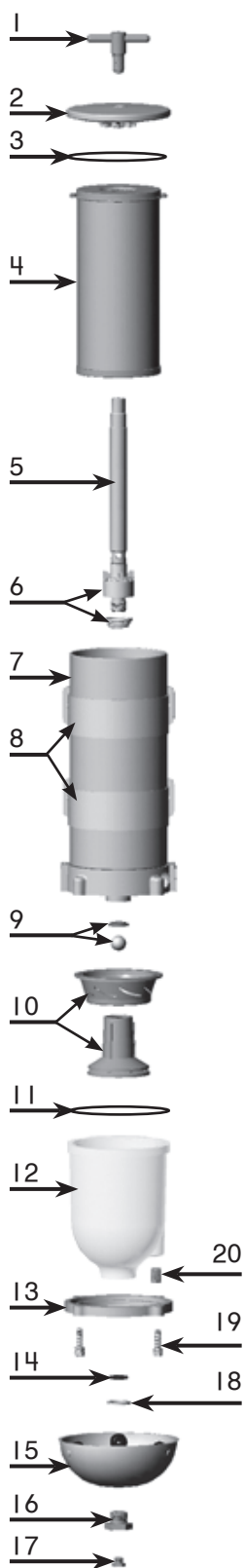

1000MA and 1003MA

Part Number	Description
1. RK11888	T-handle Kit (includes o-ring)
11350	T-handle O-ring
2. RK11-1933-04	Lid Kit (includes #3)
3. 11007	Lid Gasket
4. Replacement Element (includes #3)	
2020SMOR	2 Micron Element
2020TMOR	10 Micron Element
2020PMOR	30 Micron Element
5. RK11-1930	Return Tube Kit
6. RK11-1953	Valve, Spring & O-ring Kit
7. RK11021	Outer Cylinder Kit (include #'s 3 and 10)
8. RK11815-101	Body Bracket Kit
9. RK11028B	Checkball and Seal Kit
10. RK11026D	Turbine/Centrifuge Kit
11. 11007	Bowl O-ring
12. RK11-1606-1	Clear Bowl Kit (includes #'s 10, 13, 15-17)
RK11734	Metal Bowl Kit
RK11734-01	Metal Bowl (1/4"NPT)
13. RK11037A	Bowl Ring Kit (includes #18)
14. RK11340	Drain Fitting O-ring
15. RK11868 ¹	Heat Deflector Kit (includes #'s 13-17)
16. 918-N4	Bowl Plug (1/4" NPT)
17. RK11-1910	Bowl Drain Fitting Kit
18. RK11341	Bowl Drain Gasket Kit
19. RK11542	Capscrew Kit (4 screws) (1/4"-20 x 1")
20. RK20022	Port Plug Kit
21. 11-1853-16	Base with 1/2"-14 BSPT ports

Additional Parts (not shown)

RK19492	Shut-off Drain Valve Kit
RK21069 ²	Water Probe Kit (MA Bowls)
RK11-1679	Plastic Plug Kit
RK11-1404	Complete Service Kit
19526	Installation Instructions

¹For replacement only. The Coast Guard does not accept 'FH' units converted to 'MA' configurations.

²For diesel service only. Must be used with a Water Detection Kit.

Marine Fuel Filtration

Marine Turbine Series

How to Order

(The example below illustrates how the part numbers are constructed).

731000MA	M	10
Basic Model	Add M for metal bowl	Specify: 2 (for 2 micron) 10 (for 10 micron) 30 (for 30 micron)

Replacement Element (seals included)		
2020SM-OR	2 micron	Final
2020TM-OR	10 micron	Secondary
2020PM-OR	30 micron	Primary ¹

¹ A secondary or final filter is required downstream.

Mounting Information

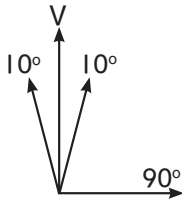

- Note:
1. Mount filter assembly as close to vertical (V) as possible. For best efficiency, do not exceed 10° from V.
 2. Do not remove valve fittings as they are integral components to the valve body.

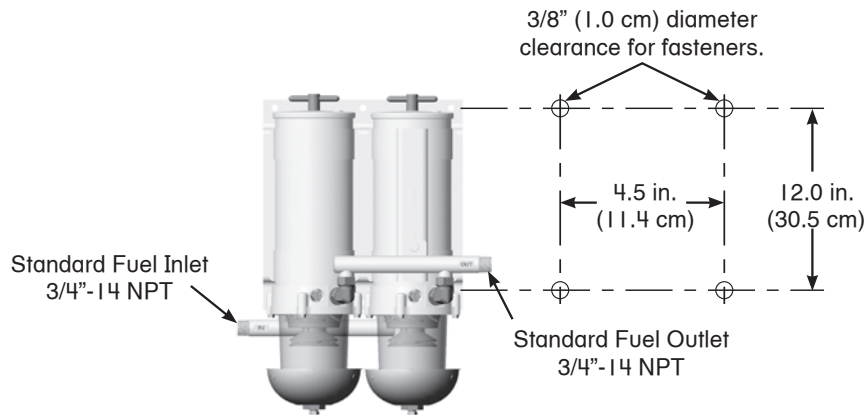

RACOR®

Technical Support:
800.344.3286 ext. 7555
racortech@parker.com

338



Marine Fuel Filtration

Marine Turbine Series

2

Replacement Parts

731000MA

Part Number

Description

- | | |
|---|--|
| 1. 1000MA | Refer to model 1000MA for a complete part breakdown. |
| 2. RK11895
11-1629
11895 | Clamp Bracket Kit
Dual unit Bracket
Clamp Bracket Assembly |
| 3. 11923 | Outlet Manifold |
| 4. 11072 | Elbow Fitting (Parker #2507-10-8) |
| 5. 11892 | Inlet Manifold |

Additional Parts (not shown)

RK19492 UL Listed Marine Valve Kit
(use two for use with this unit)

19531 Installation Instructions

For water detection kits see the marine Accessories.

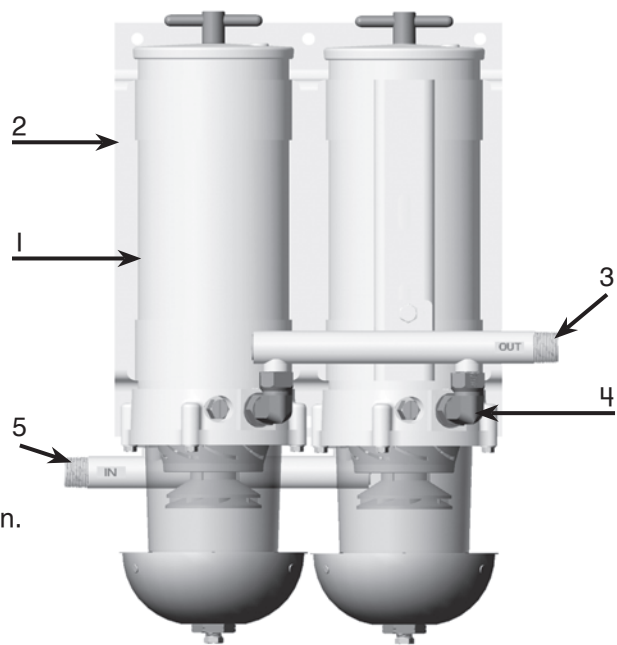

731000MA
Certifications



BUREAU
VERITAS



Marine Fuel Filtration

Marine Turbine Series

How to Order

(The example below illustrates how the part numbers are constructed).

75500MAX	M	10
Basic Model	Add M for metal bowl	Add: 2 (for 2 micron) 10 (for 10 micron) 30 (for 30 micron)

Replacement Element (seals included)		
2010SM-OR	2 micron	Final/Secondary
2010TM-OR	10 micron	Primary/Secondary
2010PM-OR	30 micron	Primary ¹

¹ A secondary/final filter is required downstream.

Mounting Information

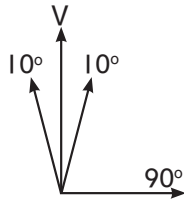

- Note:
1. Mount filter assembly as close to vertical (V) as possible. For best efficiency, do not exceed 10° from V.
 2. Do not remove valve fittings as they are integral components to the valve body.

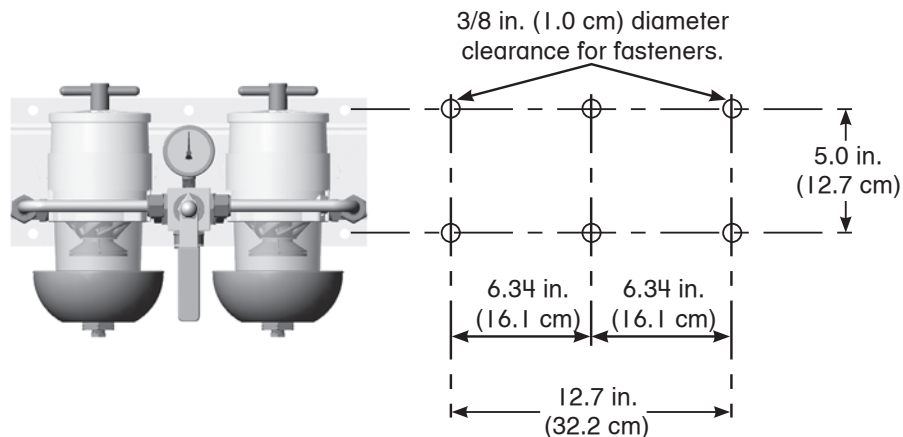

RACOR®

Technical Support:
800.344.3286 ext. 7555
racortech@parker.com

340



Marine Fuel Filtration

Marine Turbine Series

2

Replacement Parts

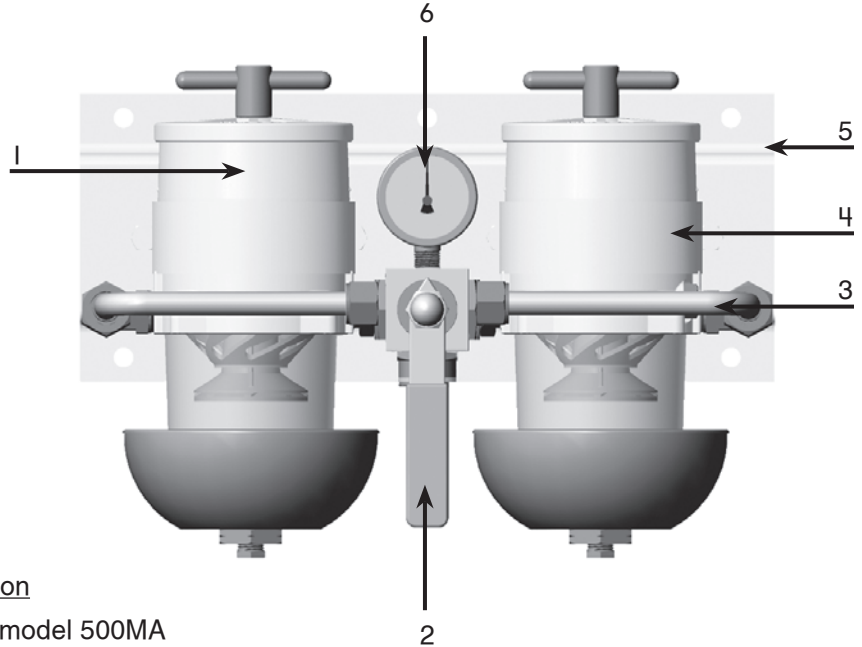

75500MAX

Part Number

Description

1. **500MA** Refer to model 500MA for a complete part breakdown.
2. **RK15390** Valve Kit
RK11-1959 Valve Replacement Kit
3. **RK15391** Rigid Tubing Kit
4. **RK15378** Body Clamp Bracket Kit (One-Piece)
RK15300 Body Clamp Bracket Kit (Three-Piece)
5. **RK15329** Main Bracket Kit
6. **RK19476** Gauge Kit

Additional Parts (not shown)

- RK19492** UL Listed Marine Drain Kit (two for use with this unit)
- 15349** Installation Instructions

75500MAX
Certifications



Marine Fuel Filtration

Marine Turbine Series

How to Order

(The example below illustrates how the part numbers are constructed).

75900MAX	M	I0
Basic Model	Add M for metal bowl	Add: 2 (for 2 micron) 10 (for 10 micron) 30 (for 30 micron)

Replacement Element (seals included)		
2040SM-OR	2 micron	Final
2040TM-OR	10 micron	Secondary
2040PM-OR	30 micron	Primary ¹

¹ A secondary or final filter is required downstream.

Mounting Information

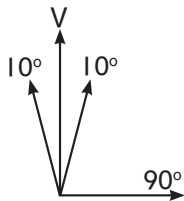

- Note:
1. Mount filter assembly as close to vertical (V) as possible. For best efficiency, do not exceed 10° from V.
 2. Do not remove valve fittings as they are integral components to the valve body.

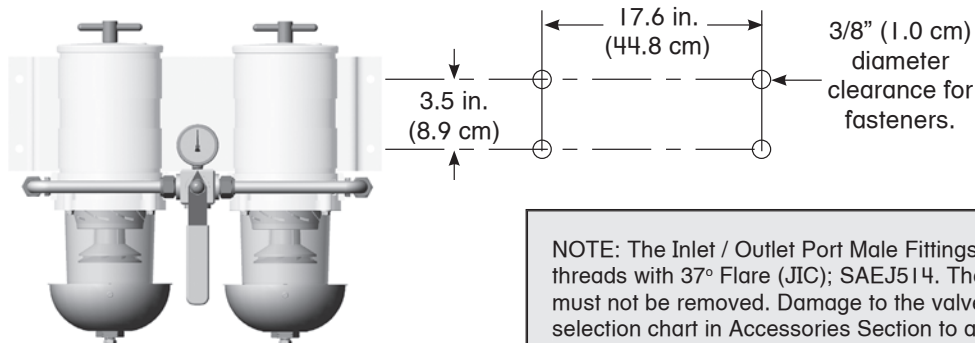

NOTE: The Inlet / Outlet Port Male Fittings are 7/8"-14 UNF threads with 37° Flare (JIC); SAEJ514. These permanent fittings must not be removed. Damage to the valve may result. See fittings selection chart in Accessories Section to adapt to your fuel system piping requirements.

RACOR

Technical Support:
800.344.3286 ext. 7555
racortech@parker.com

Marine Fuel Filtration

Marine Turbine Series

2

Replacement Parts

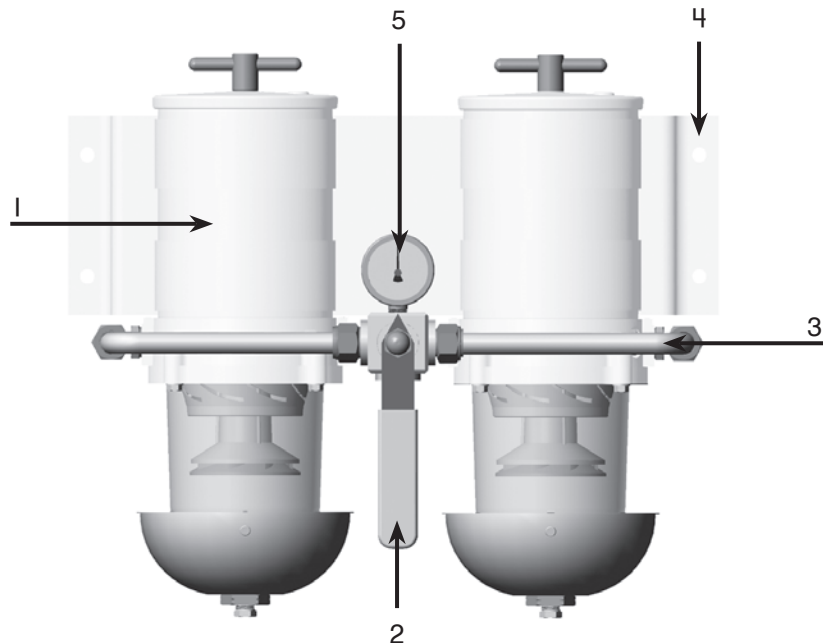

75900MAX

<u>Part Number</u>	<u>Description</u>
1. 900MA	Refer to model 900MA for a complete part breakdown.
2. RK19473 RK19506	Valve Kit Valve Service Kit
3. RK19475	Rigid Tubing Kit
4. RK19486	Dual unit Bracket Kit
5. RK19476	Gauge Assembly Kit

75900MAX
Certifications



Additional Parts (not shown)

RK19492	UL Listed Marine Valve Kit (two for use with this unit)
19536	Installation Instructions



Marine Fuel Filtration

Marine Turbine Series

How to Order

(The example below illustrates how the part numbers are constructed).

751000MAX	M	10
Basic Model	Add M for metal bowl.	Add: 2 (for 2 micron) 10 (for 10 micron) 30 (for 30 micron)

Replacement Element (seals included)		
2020SM-OR	2 micron	Final/Secondary
2020TM-OR	10 micron	Primary/Secondary
2020PM-OR	30 micron	Primary ¹

¹ A secondary or final filter is required downstream.

Mounting Information

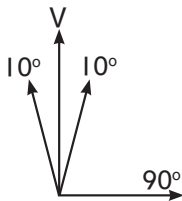

- Note:
1. Mount filter assembly as close to vertical (V) as possible. For best efficiency, do not exceed 10° from V.
 2. Do not remove valve fittings as they are integral components to the valve body.

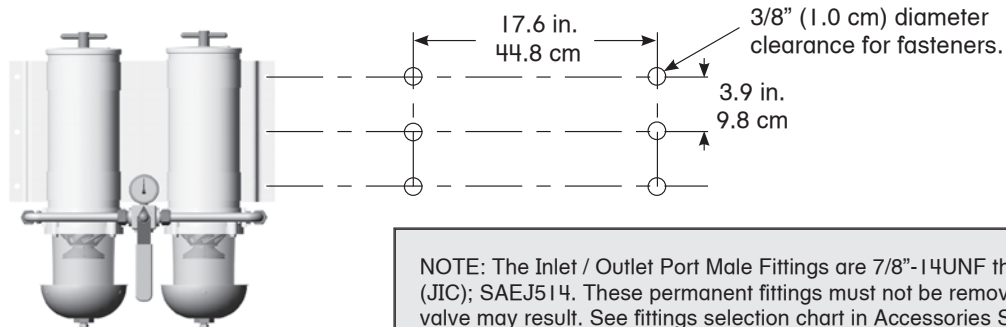

NOTE: The Inlet / Outlet Port Male Fittings are 7/8"-14UNF threads with 37° Flare (JIC); SAEJ514. These permanent fittings must not be removed. Damage to the valve may result. See fittings selection chart in Accessories Section to adapt to your fuel system piping requirements.

RACOR

Technical Support:
800.344.3286 ext. 7555
racortech@parker.com

344



Marine Fuel Filtration

Marine Turbine Series

2

Replacement Parts

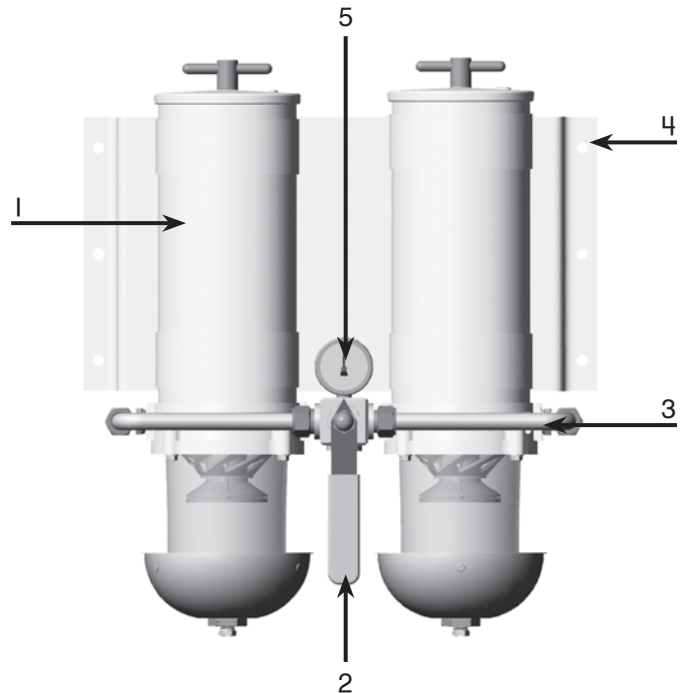

751000MAX

<u>Part Number</u>	<u>Description</u>
1. 1000MA	Refer to model 1000MA for a complete part breakdown.
2. RK19473	Valve Assembly Kit
RK19506	Valve Service Kit
3. RK19475	Rigid Tubing Assembly Kit
4. RK11-1777	Dual unit Bracket Kit
5. RK19476	Gauge Assembly Kit

751000MAX
Certifications



Additional Parts (not shown)

RK19492	UL Listed Marine Drain Valve Kit (two for use with this unit)
19536	Installation Instructions



Marine Fuel Filtration

Marine Turbine Series

How to Order

(The example below illustrates how the part numbers are constructed).

771000MA	M	10
Basic Model	Add M for metal bowl.	Add: 2 (for 2 micron) 10 (for 10 micron) 30 (for 30 micron)

Replacement Element (seals included)		
2020SM-OR	2 micron	Final/Secondary
2020TM-OR	10 micron	Primary/Secondary
2020PM-OR	30 micron	Primary ¹

¹ A secondary or final filter is required downstream.

Mounting Information

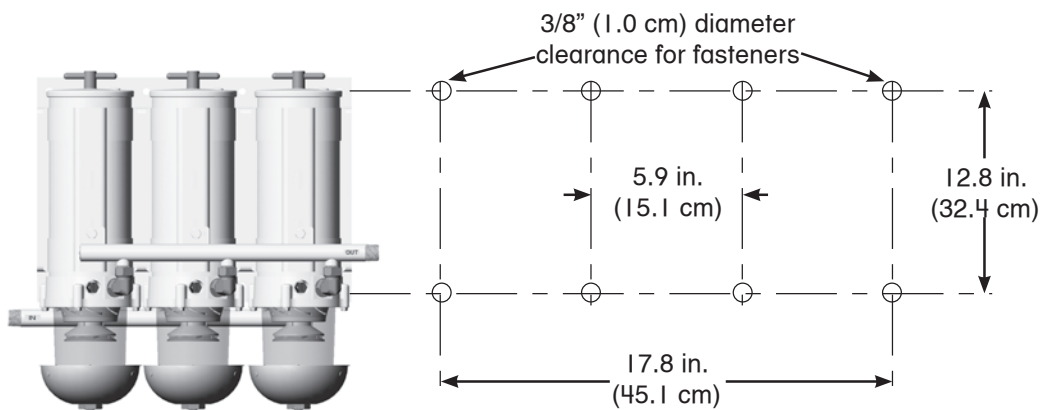

RACOR

Technical Support:
800.344.3286 ext. 7555
racortech@parker.com

346



Marine Fuel Filtration

Marine Turbine Series

2

Replacement Parts

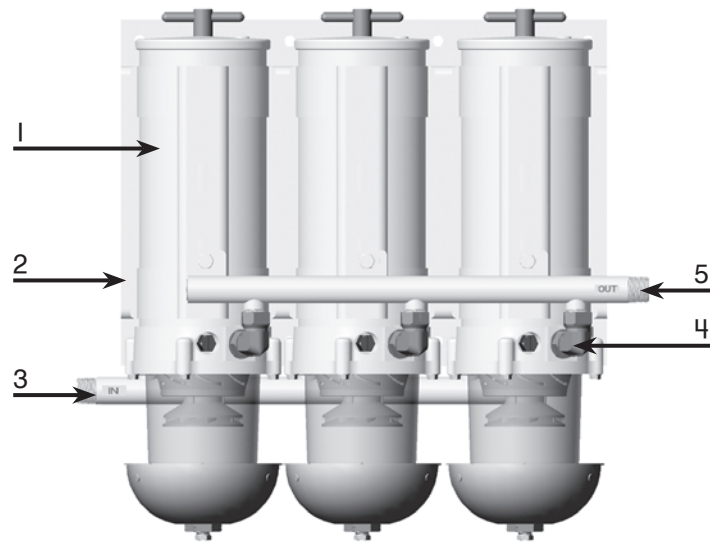

771000MA

Part Number	Description
1. 1000MA	Refer to model 1000MA for a complete part breakdown.
2. RK11895 11-1632 11895	Clamp Bracket Kit Triple unit Bracket Clamp Bracket Assembly
3. 11893	Inlet Manifold
4. 11072	Elbow Fitting (Parker #2507-10-8)
5. 11902	Outlet Manifold

771000MA
Certifications



Additional Parts (not shown)

RK19492	UL Listed Marine Drain Valve Kit (three for use with this unit)
19531	Installation Instructions

For Water Detection Kits and Manifold Conversion Kits, see the Accessories Section.



Marine Fuel Filtration

Marine Turbine Series

How to Order

(The example below illustrates how the part numbers are constructed).

791000MAV	M	I0
Basic Model	Add M for metal bowl.	Add: 2 (for 2 micron) 10 (for 10 micron) 30 (for 30 micron)

Replacement Element (seals included)		
2020SM-OR	2 micron	Final
2020TM-OR	10 micron	Secondary
2020PM-OR	30 micron	Primary ¹

¹ A secondary or final filter is required downstream.

Mounting Information

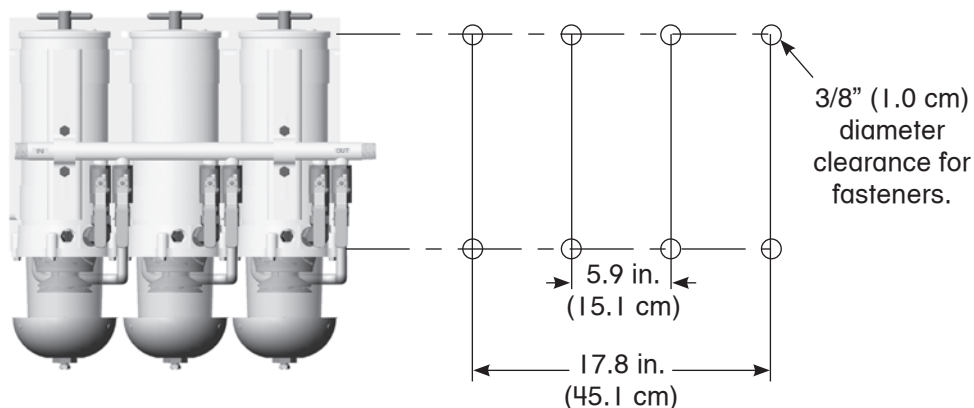

RACOR

Technical Support:
800.344.3286 ext. 7555
racortech@parker.com

348



Marine Fuel Filtration

Marine Turbine Series

2

Replacement Parts

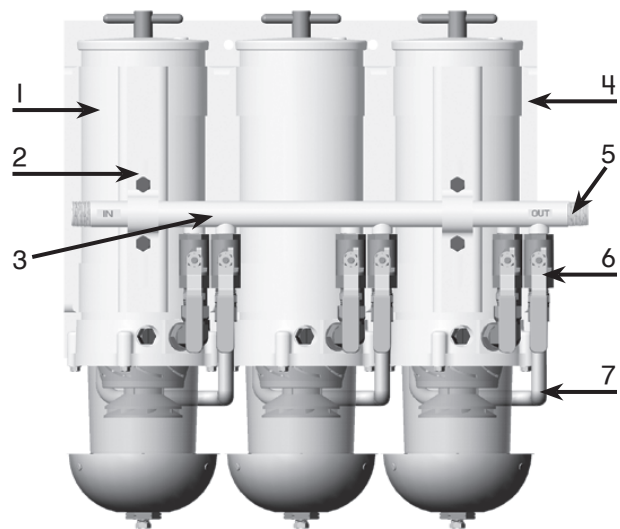

791000MAV

	<u>Part Number</u>	<u>Description</u>
1	1000MA	Refer to model 1000MA for a complete part breakdown.
2	11-1632	Triple unit Bracket
3	19460	Inlet Manifold
4	11895 11-1761	Clamp Bracket 'U' Bracket
5	19461	Outlet Manifold
6	RK11073	1/2" Ball Valve Kit
7	11-1626	Formed Tubing Assembly

Additional Parts (not shown)

RK19492 UL Listed Marine Drain Valve Kit (three for use with this unit)

19523 Installation Instructions

For water detection kits and manifold conversion kits - see the marine accessories section.

791000MAV
Certifications



Marine Fuel Filtration

Marine Turbine Series

Test Data

(Test results are from controlled laboratory testing, field results may vary.)

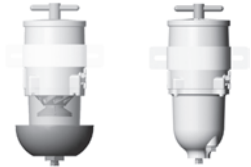

500MA 500MAM

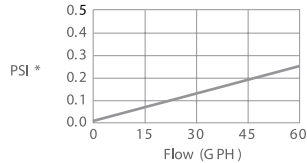

SAE J 905 Fuel Flow Restriction

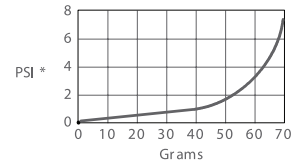

SAE J 905 Solids Capacity
(using SOFT C-2A; 2010TM Element)



900MA 900MAM

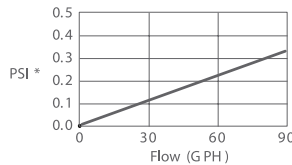

SAE J 905 Fuel Flow Restriction

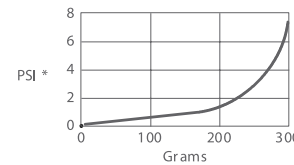

SAE J 905 Solids Capacity
(using SOFT C-2A; 2040TM Element)



1000MA 1000MAM

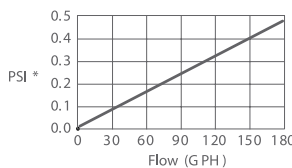

SAE J 905 Fuel Flow Restriction

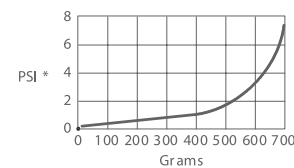

SAE J 905 Solids Capacity
(using SOFT C-2A; 2020TM Element)



731000MA

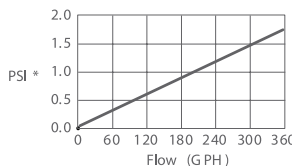

SAE J 905 Fuel Flow Restriction

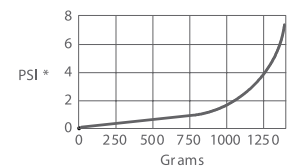

SAE J 905 Solids Capacity
(using SOFT C-2A; 2020TM Element)

*PSI X 2.036 = inHg. / PSI X 6.895 = kPa

Marine Fuel Filtration

Marine Turbine Series

2

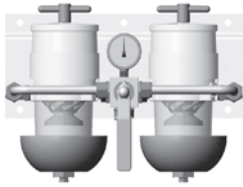

75500MAX

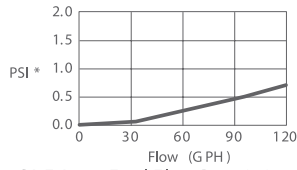

SA E J 905 Fuel Flow Restriction

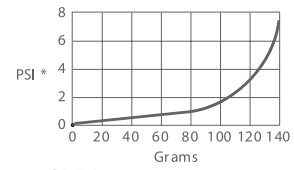

SA E J 905 Solids Capacity
(using SOFT C-2A; 2010TM Element)



75900MAX

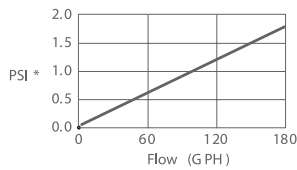

SA E J 905 Fuel Flow Restriction

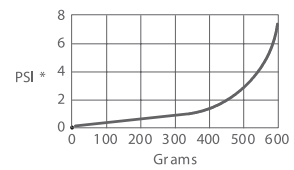

SA E J 905 Solids Capacity
(using SOFT C-2A; 2040TM Element)



751000MAX

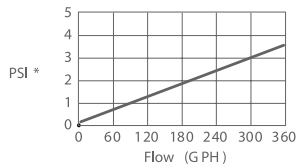

SA E J 905 Fuel Flow Restriction

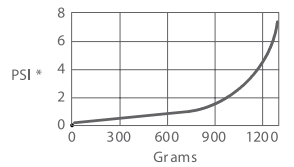

SA E J 905 Solids Capacity
(using SOFT C-2A; 2020TM Element)



771000MA

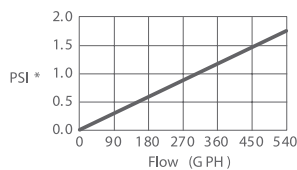

SA E J 905 Fuel Flow Restriction

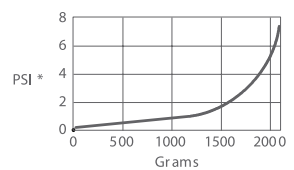

SA E J 905 Solids Capacity
(using SOFT C-2A; 2020TM Element)

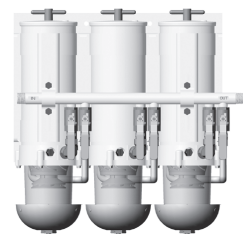

791000MAV

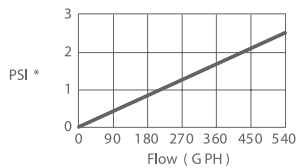

SA E J 905 Fuel Flow Restriction

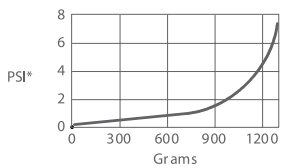

SA E J 905 Solids Capacity
(using SOFT C-2A; 2020TM Element)

*PSI X 2.036 = inHg. / PSI X 6.895 = kPa

Marine Fuel Filtration

Marine Turbine Series

Installation Instructions

New filter installations must be filled with fuel and the fuel system must be adequately primed following the engine manufacturer's recommendations. Existing installation difficulties are usually associated with improper priming procedures or damage to the unit or fuel system. The result is either internal air suction or external fuel leakage. Diagnose with the following steps:

1. Check fuel tank level and verify fuel delivery valves are open.
2. Verify T-handle, bowl fasteners and fuel fittings are tight and bowl drain is closed.
3. If element is new, check potential restriction at fuel tank draw tube. An in-tank strainer may be plugged.
4. Review other troubleshooting instructions to uncover other solutions.

Correct external fuel leaks immediately! These conditions result in reduced engine performance such as: hard starting, stalling, reduced power and fire hazards.

Correct Application

It is very important that Turbine Series filter assemblies are not 'under specified' for the application. The maximum fuel flow rating of the filter assembly must not be exceeded; doing so will reduce efficiency and de-gas (pull air from) the fuel.

Filter Elements

Replacement elements are available in 2, 10 and 30 micron ratings (nominal). Filtration needs are based on application, fuel quality, maintenance schedules and operating climates. A simple rule to remember is... the finer the filtration, the more frequent the filter change interval.

Always carry extra replacement elements with your equipment as one tankful of excessively contaminated fuel can plug an element quickly.

When clogged to maximum capacity, elements will have a brown to black color or tar like contaminants may be present - this is normal. An appearance of a multi-colored slime (which may have a foul odor) is an indication of microbiological contamination. This condition must be treated immediately. Racor offers a wide variety of gasoline and diesel additives to prevent and treat these problems; see 'Additives' section of this catalog. Severe conditions must be corrected by a repair facility.

Never operate a filter assembly without the element in place.

The element safety valve on the fuel return tube will not expose the outlet hole if the element is removed. Instead, punch the emergency tab on the top of the element and leave in place.

Warning! Puncturing the emergency tab will bypass all filtration and send unfiltered fuel to your engine. Service the element as soon as possible to avoid harmful contaminants flowing downstream to the engine.

Water Sensors

This feature alerts the operator of a high-water condition. The bowl must be drained of water at the earliest convenience.

A Racor water detection module is needed to work with the in-bowl sensor.

The unit should activate when the water reaches the sensor tips (and when they measure below 47,000 or 100,000 ohms of resistance, depending on the detection module used). If not, the tips may be fouled with a coating. Remove the sensor and clean the tips with a cloth. Run a jumper wire between the tips with the ignition ON to test the system. Difficulties usually lie in the wire connections, power source, or an independent ground.

RACOR[®]

Technical Support:
800.344.3286 ext. 7555
racortech@parker.com

Marine Fuel Filtration

Marine Turbine Series

2

All Marine Turbine Series filters are 100% tested to ensure a leak-proof, quality product.

Apply Parker Super O-lube (part number RK31605) or equivalent to all seals at major attachment points to maintain integrity, seal elasticity, to fill small voids and provide protection from degradation.

Perform the following checks with the engine OFF (and applicable valves closed). For replacement parts, refer to the appropriate 'Replacement Parts' section of this catalog.

Damaged, worn, or dirty seals will allow air ingestion. Inspect and replace all seals as needed. Lube all seals with Parker Super O-lube. Clean sealing surfaces of dirt or debris every time element is replaced.

Hand tighten T-handle; do not use tools!

If element is changed or assembly drained for any reason, repriming assembly (filling with fuel) may be necessary. Fill to just above top of

Do not overtighten carriage bolt as this may distort cylinder roundness.

Do not overtighten self-tapping screws; this may strip the threads. After disassembly, start screws by hand prior to using tools. Specification: 55 to 65 in.

The hollow aluminum check-ball floats up against the seal when the fuel is stopped thus preventing fuel bleed-back. If your unit loses prime, inspect upstream hose connections first, otherwise, disassemble the unit and inspect the seal and ball.

Drain water before it reaches this level.

Air bubbles or fuel leakage appearing from drain may indicate that drain is closed completely or that seal has been clogged with contaminants. Tighten drain and inspect: If self-venting drain will not work when opened, it may be clogged. Cycle drain (open-close) or attach a hose and briefly apply air (<2-3 PSI with T-handle and lid removed) to dislodge contaminants.

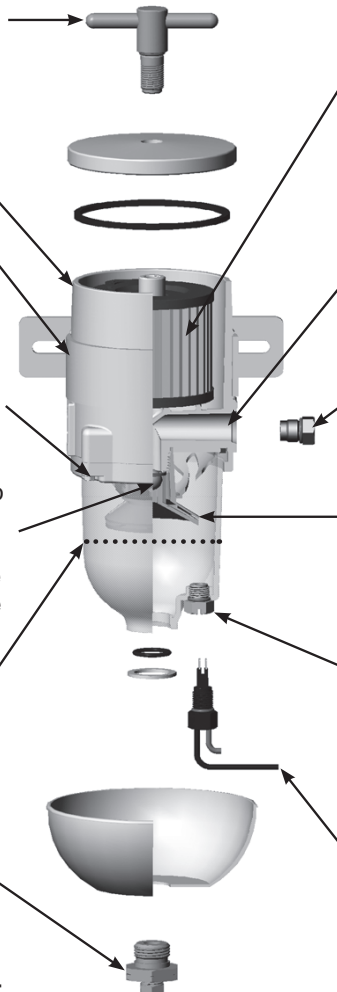

Element should be replaced every 10,000 miles every 500 hours, every other oil change, annually or at first indication of power loss, whichever occurs first. Construction and agricultural equipment should change element every 300 hours.

SAE O-ring ports should have a smooth angled seat for sealing. Do not scratch this surface. Check O-ring for damage. Replace if necessary.

Heater feed-thru O-ring must not be damaged or swollen. Tighten snugly. Specification: 15 to 20 in. lbs.

Air bubbles appearing from turbine are an indication of an upstream leak between Racor inlet and fuel tank pick-up tube.

A water sensor plug is standard equipment on new assemblies. Water sensor kits are available as accessories; see the 'Accessories' section of this catalog. Tighten plug or water sensor snugly. Specification: 15 to 20 in. lbs.

Water sensors activate when water contacts the sensor tips. Air bubbles or fuel leakage appearing from sensor area may indicate that it is loose or O-ring is damaged. Tighten or disassemble and inspect. Specification: 15 to 20 in. lbs.

